

ground strap

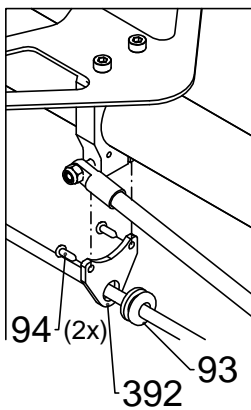

O-Rings!
Don't forget!

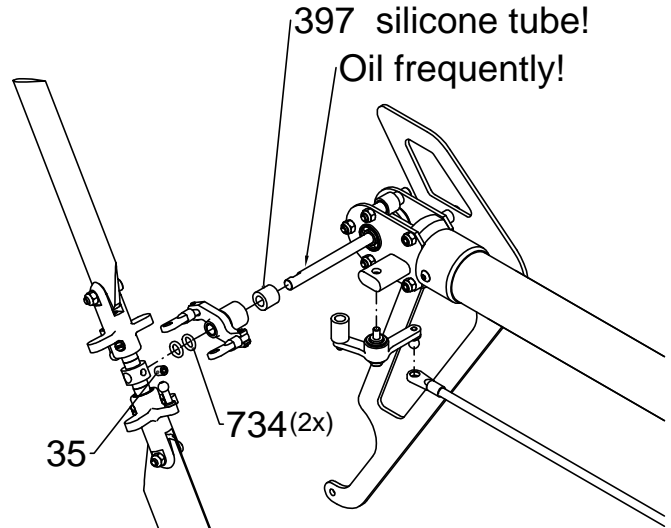
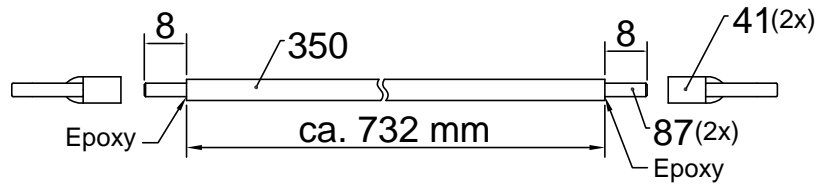
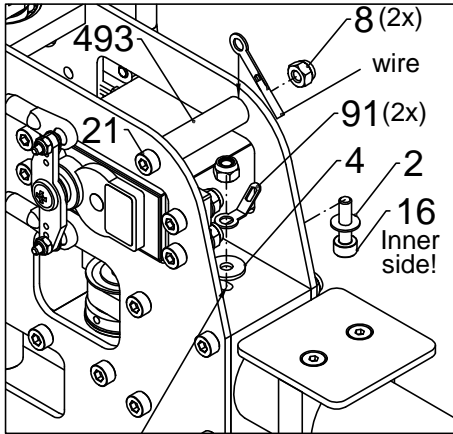
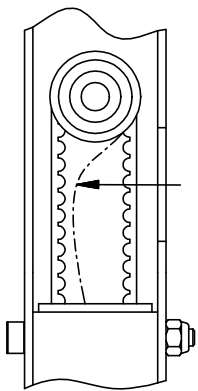

belt should not touch other side of belt (press with thumb)

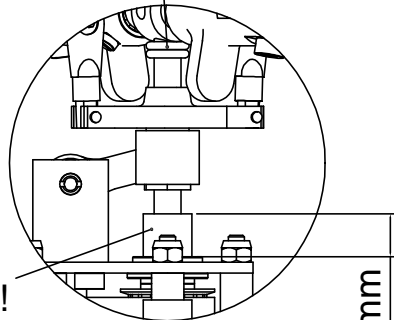

Silicone tube!
Don't forget!

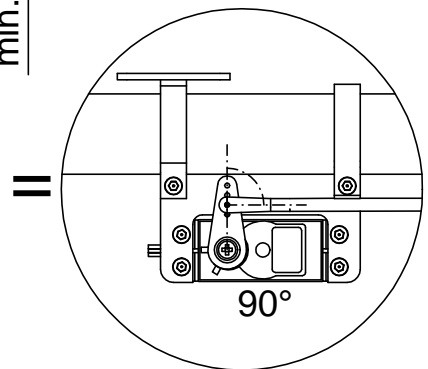
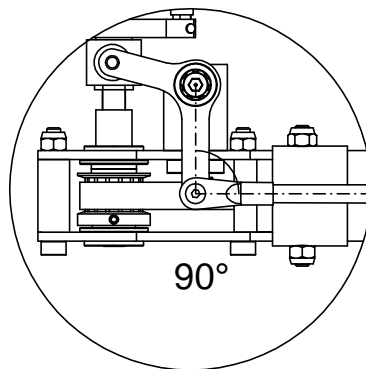
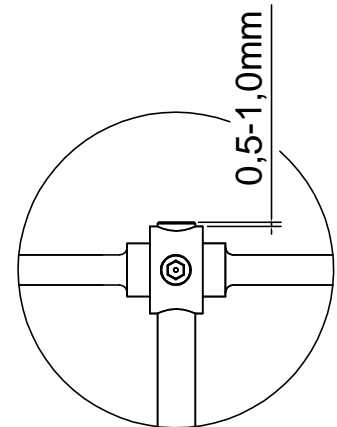

- 2 = washer M3
- 4 = washer M3 large
- 6 = clevis 2.5 PA
- 8 = lock nut M3
- 16 = hexagon screw M3 x 12
- 35 = grub screw M4 x 5
- 41 = ball joint 2.5
- 87 = control rod 2.5 x 26
- 94 = self tapping screw 2.2 x 6.5